



Installation Manual

*Model
650R*



WARRANTY

Alert Warranty Information

Product warranty returns must only be submitted by an authorized dealer.

All Alert models have a Limited Lifetime Warranty on the main control module.

All parts excluding the control module have a two year warranty against defects in workmanship. This includes the shock sensors, remote transmitters and sirens. The control module will be repaired or replaced at our discretion for up to a 24 month period at no charge. After 24 months a \$30.00 fee will be charged for repair or replacement of the control module.

Removal and reinstallation charges are not the responsibility of JBS Technologies, LLC the manufacturer of Alert. Warranty registration must be completed within 14 days of the original date of purchase. Registration can be mailed in or performed on line at www.alertautomotive.com. JBS Technologies makes no warranty against the theft of a vehicle or its contents. This warranty only extends to the original system purchaser and the vehicle it was originally installed on.

Limitation of Remedies

The purchasers remedy is limited to the repair or replacement of the unit and in no event shall exceed the purchase price. Incidental, consequential and or indirect damages are expressly disclaimed. No person or entity is authorized to alter or amend this limited lifetime warranty.

TABLE OF CONTENTS

INSTALLATION DIAGRAMS	7-8
H1: 6 PIN HEAVY GAUGE WIRING CONNECTION	9
H1/1 Violet Wire – Starter Output.....	9
H1/2 & H1/3 Red Wire – +12V Power Input	9
H1/4 Yellow Wire – Ignition 1 Output	9
H1/5 Pink Wire – Ignition 2 Output	9
H1/6 Brown Wire – Accessory Output (Heater /ACC Output).....	10
H2: 5 PIN WIRE HARNESS	10
H2/1 Red / White wire – Parking Light Relay Power Input.....	10
H2/2 White wire – Parking Light Relay Output	10
H2/3 Black wire – System Ground	10
H2/4 Brown wire – Siren Drive Output.....	11
H2/5 Red wire – System Power	11
H3: BLACK 4-PIN CONNECTOR FOR TWO-WAY TRANSCIEVER/ANTENNA MODULE	11
H5: 9 PIN MINI BLACK INPUT WIRE CONNECTOR	11
H5/1 Grey wire – (-) Negative Safety Shut Down For Hood Pin Switch	11
H5/2 Brown / Red wire – (+) Positive Safety Shut Down Brake or Handbrake	12
H5/3 Black / White wire – (-) Neutral Safety Switch or (-) Remote Toggle Switch Input	13
H5/4 Blue /White wire – (-) Instant Trigger or Major Trigger Input (Zone 2)	13
H5/5 Grey / Black wire – (-) Diesel Wait - To - Start Input	13
H5/6 Green wire – (-) Negative Door Pin Switch Input (Zone 3).....	13
H5/7 Violet Wire – (+) Positive Door Pin Switch Input (Zone 3)	14
H5/8 White / Black wire – (-) Instant Start & Turn Off Input.....	14
H5/9 Violet / White wire – Tach Input or Oil Sensor Connection	14
H6: 3 PIN DOOR LOCK CONNECTOR	15
Adding New Actuator	15
Type “A” Positive Trigger Door Lock System.....	15
Type “B” Negative Trigger Door Lock System.....	15
Type “C” 5-wire Door Lock System.....	15
2 Steps Door Unlock Wire Connections For Type “C” 5 Wires Alternating Door Lock System	15
Vacuum Operate Door Locking System	16
2 Steps Door Unlock Wire Connections For Type “B” Negative Switched Door Lock System	16
2 Steps Door Unlock Wire Connections For Type “A” Positive Switched Door Lock System.....	16 3

TABLE OF CONTENTS

H7: 4 PIN ORANGE CONNECTOR FOR 2 STAGE SHOCK SENSOR (ZONE 1 / 4)	17
H8: 10-PIN MINI WHITE OUTPUT WIRE CONNECTOR	17
H8/1 Blue /Black wire – (-) 200mA Ignition 3 Control Output	17
Transponder Interfacing	
GM VATS Key Override	
H8/2 Black / Violet wire – (-) 200mA Channel 6 Programmable Output	17
H8/3 Brown / Black wire – (-) 200mA Programmable Output.....	18
Horn Output – (Factory Default Setting)	
Factory Security Rearm Signal Output	
H8/4 Black / White wire – (-) 200mA Dome Light Supervision Output	18
H8/5 Black / Red wire – (-) 200mA Channel 5 Programmable Output	18
H8/6 Purple / Black wire – (-) 200mA Programmable Output.....	19
Channel 4 Programmable Output – (Factory Default Setting)	
Ground Output During Start (Crank)	
H8/7 Red / White wire – (-) 200mA Channel 3 (Trunk) Output.....	19
H8/8 LT. Green / Black wire – (-) 200mA Programmable Output.....	20
Dual Pulse Door Unlock Output (Factory default setting)	
Factory Security Disarm Signal Output	
Start Status (Shock Sensor By-Pass Control) Output	
H8/9 Orange / White wire – (-) 200mA Grounded Output When Disarmed.....	20
H8/10 Orange wire – (-) 200mA Grounded Output When Armed	21
H9: 2 PIN BLUE CONNECTOR FOR THE VALET/PROGRAMMING SWITCH	21
H10: 2 PIN WHITE CONNECTOR FOR THE LED STATUS INDICATOR	21
PROGRAMMING & TESTING:	
A. AUTOMATIC / MANUAL TRANSMISSION VEHICLE	21
B. PROGRAMMING THE REMOTE TRANSMITTER	22-23
C. FEATURES PROGRAMMING	23
Alarm Feature #1 Programming	23-24
Active Arming With Passive Starter Disables	
3 / 45 seconds Delay Door Ajar Error Chirp	
Alarm Feature #2 Programming	24-26
Comfort Feature	
Password Pin Code Setup	

TABLE OF CONTENTS

Alarm Feature #3 Programming	26-29
Channel 4 (5 / 6) Timer Control Output Programming	
Ground Output During Start (Crank) Programming	
Start Feature #1 Programming	29-31
Safe Start (Child Safety Mode)	
Temperature Start Programming	
Start Feature #2 Programming	31
Engine Checking TACH. – RPM Learning & Testing	32-33
Engine Checking Voltage – Start Timer Set-up & Testing	33-34
Engine Checking Oil Sensor – Start Timer Set-up & Testing	34-35
Test Mode	35-36
Turbo Mode	
Range Check	
RETURN TO FACTORY DEFAULT SETTING	36
SHUTDOWN DIAGNOSTICS	37-38
TESTING YOUR INSTALLATION	38-42
Test the Brake shutdown circuit	
Test the Hood Pin shutdown circuit	
Neutral Start Safety Test	
Mechanical Neutral Safety Switch Considerations	
Park/Neutral ECM Input	
Key In Sensor Circuits	

IMPORTANT NOTICE

This remote starter with keyless entry system is designed to be installed on fuel injected vehicles only.

- This system must be installed and wired through a safety switch to assure that it will not start in any forward or reverse gear.
- Some automatic transmission vehicles [mainly older GM models with a purple starter wire] have a mechanical-type park mechanism instead of an electrical safety switch. The mechanical type does not interrupt the starter circuit when the transmission is in any gear and does not offer the 100% level of safety required for remote starting purposes. Therefore, you must create a circuit that will prevent the remote starter from engaging when the key is in the ignition.
- Once you install this system, you must verify that the vehicle will not start in any forward or reverse gear.

IMPORTANT NOTICE

- Read the operation manual for operating and programming routine.
- Do not install any component near the brake, gas pedal or steering linkage.
- Most vehicles have an SRS air bag system. Use extreme care and do not probe any wires of the SRS system. These wires will almost always be located inside a bright yellow tube located near the steering wheel column.
- Check behind panels before drilling any holes. Ensure that no wiring harness or other components are located behind the panels that would otherwise be damaged.
- Do not use conventional crimp lock or bullet connectors on any wiring.
- Do not disconnect the battery if the vehicle has an anti-theft radio or is equipped with an airbag. Doing so may cause a warning light to be displayed and the radio to stop functioning.
- Do not leave the interior or exterior lights on for an extended period of time. Remove the dome light fuse from the vehicles fuse box.
- Do not mount the control module until all connections have been made and the unit is programmed and tested.
- Finally place the warning sticker under the hood when the installation is completed.

COMPONENTS

- 1- Main Control Module
- 2- Four Button Remote Transmitters
- 1- 6 Pin Ignition Harness
- 1- 5 Pin Harness
- 1- 10 Pin Mini Output Harness
- 1- 9 Pin Mini Input Harness
- 1- 2 Pin Valet Switch
- 1- 2 Pin Led Light Harness
- 1- 4 Pin Antenna Harness
- 1- 3 Pin Door Lock Harness
- 1- 4 Pin Shock Sensor Harness
- 1- Six Tone Mini Siren
- 1- Hood Switch
- 1- Hood and Window Decal
- 1- Installation Manual
- 1- Owners Manual

INSTALLATION DIAGRAM

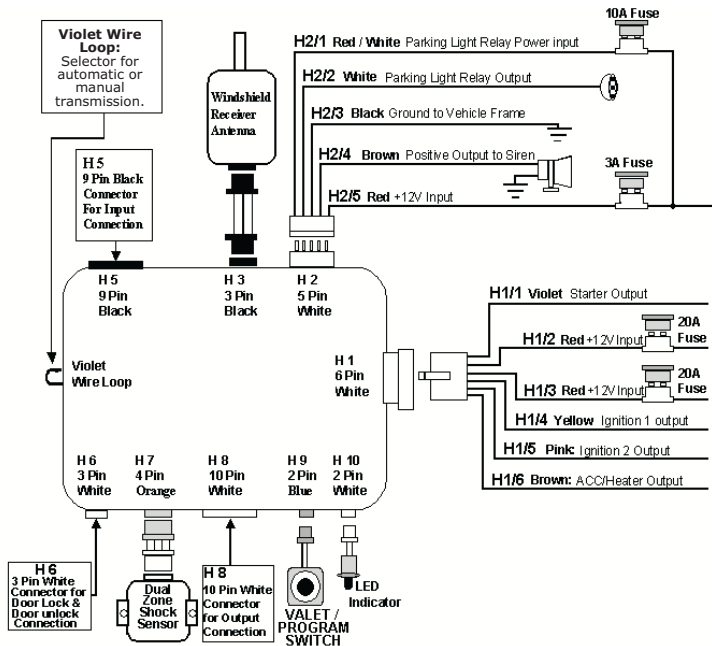

WIRING HARNESSSES

H5 9-Pin BLACK Harness

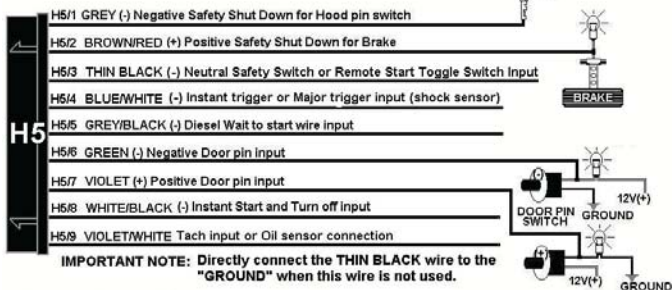

H8 10-Pin WHITE Harness

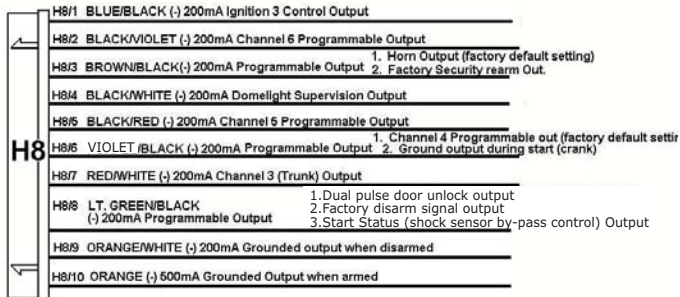

Keep all wiring away from moving engine parts, exhaust pipes and high-temperature cable. Tape wires that pass through holes in the firewall to prevent fraying. Watch out for sharp edges that may damage wires and cause short circuits.

CAUTION: Do not connect the wire harness to the control module until all wiring to vehicle is complete.

WIRING CONNECTIONS

H1: 6-PIN HEAVY GAUGE WIRING CONNECTIONS:

Remember that the system is designed to duplicate the same functions of the ignition key switch! Since this installation will require analysis of the ignition switch functions, we recommend making the H1 harness connections directly to the ignition switch wires.

H1/1 VIOLET Wire—(Starter Crank Output)

Connect the **VIOLET** wire to the starter crank wire at the ignition switch harness. This wire show **+12 volts** when the ignition switch is turned to the **"start"** or **"crank"** position only. This wire will test 0 volts in all other ignition switch positions

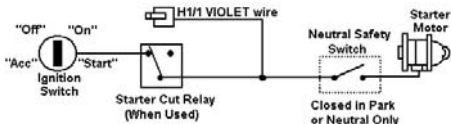

H1/2 and H1/3 RED Wires (2)-(+12V Power Input)

Remove the **(2) two 20A fuses** prior to connecting these wires and do not replace them until the satellite harness has been plugged into the control module. These two wires are the source of current for all the circuits the relay satellite will energize. They must be connected to a high current source. Since the factory supplies **(+) 12V** to the key switch, it is recommended you make your connections there.

Note: If the factory supplies two separate **(+) 12V** feeds to the ignition switch, connect **(1) RED** wire of the satellite to each feed at the switch.

H1/4 YELLOW Wire – (Ignition 1 Output)

Connect the **YELLOW** wire to the ignition 1 wire from the ignition switch. The ignition wire should receive **"12 volts"** when the ignition key is in the **"on"** and **"start"** or **"crank"** positions. When the ignition is turned **"off"**, the ignition wire should receive **"0" voltage**. **The YELLOW wire must be connected.**

H1/5 PINK Wire – (Ignition 2 Output)

Some vehicles have 2 ignition wires that must be connected. Attach the **PINK** wire to the ignition 2 wire from the ignition switch. The ignition wire should receive **" +12 volts "** when the ignition key is in the **"on"** or **"run"** and **"start"** or **"crank"** positions. When the ignition is turned to the **"off"** position this wire will show **"0" voltage**. If the **PINK** wire is not used, cap or tape the end of the wire.

On some GM vehicles, the second ignition wire may also show voltage in Off of Accessory positions. There will be **"0" voltage** when the key is removed (Lock position).

WIRING CONNECTIONS

H1/6 BROWN Wire –Accessory Output (Heater /AC Output)

Connect the **BROWN** wire to the Accessory/Heater-Blower wire in the vehicle that powers the Heater/AC system. The Accessory/Heater-Blower wire will show “+ 12 volts” when the ignition switch is turned to the “**accessory**”(some vehicles) “**on**” or “**run**” positions, and will show “**0**” volts when the key is turned to the “**off**” and “**start**” or “**crank**” positions. On some vehicles, there will often be more than one Accessory/Heater-Blower wire in the ignition harness. The correct Accessory/Heater-Blower wire will power the vehicle’s Heater/AC system. **Note:** Some vehicle may have separate wires for the blower motor and the air conditioning compressor such as Ford products. In such cases, it will be necessary to add a relay to power the second Accessory/Heater-Blower wire, if your vehicle does not have a Ignition 2 wire, use the **Ignition 2 Output (H1/5 PINK)** wire from the remote starter to power up the second Accessory/Heater-Blower wire.

H2:5 PIN WIRE HARNESS:

H2/1 RED / WHITE Wire (Parking Light Relay Input)

The **RED/WHITE** wire is the input for the parking light relay. This wire will determine the output polarity of the parking light relay.

If your vehicle requires **+12volts** to power the parking light circuit you will not need to connect this wire. This wire is already connected to the **+12 volt** constant **RED** wire in the same harness.

If your vehicle’s parking light circuit operates on a switched **(-)** **negative** ground then cut the **RED/WHITE** wire from the **RED** wire and attach it directly to a ground source. **Note: Make sure to tape the RED wire at the cut location.**

H2/2 WHITE Wire (Parking Light Relay Output)

Connect the **WHITE** wire to the wire that powers the parking light circuit on the vehicle. The **WHITE** parking light wire is rated at 10amps max and should not exceed this current. If your vehicles parking light system requires more than **10amps you must add a relay** to power the parking light system

H2/3 BLACK Wire (System Ground)

This is the main ground connection of the control module. Make this connection to a solid section of the vehicles frame ground.

WIRING CONNECTIONS

H2/4 BROWN Wire (Siren Output)(Factory Default setting)

The **BROWN** wire will provide a (+) **positive** output for the optional siren. Also programmable for horn output (relay required).

H2/5 RED Wire (System +12volt Constant Power)

Connect the **RED** wire to a constant **+12 volt** source.

The **RED** wire supplies power to the system. Connect this wire to a constant **+12 volt** source.

H3: BLACK 4-PIN CONNECTOR,

TWO-WAY TRANCEIVER/ANTENNA MODULE

The two-way transceiver/antenna mounts on the location above the belt line (dashboard) of the vehicle for best reception. We suggest you mount it on the lower left or upper left-hand side of windshield. **Warning!** Do not mount in such a manner that it obstructs the driver's view.

- Remove the protective tape backing.
- Carefully align the two-way transceiver/antenna and apply to the windshield.
- Route the black connector wire behind the trim and connect to the two-way transceiver/antenna.
- Connect the other end to the control module.
- Special considerations must be made for windshield glass as some newer vehicles utilize a metallic shielded window glass that will inhibit or restrict RF reception. In these vehicles, route the two way transceiver/antenna module away from metallic shielded window glass as far as possible.

H5 9-PIN BLACK WIRING HARNESS:

H5/1 GREY Wire (-) (Negative Safety Shut Down For Hood Switch)

This wire provides an instant shutdown for the remote start, whenever it is grounded. Connect the wire to the hood pin switch previously installed. This wire must be routed through a grommet in the firewall and connected to the hood pin switch. If the pin switch is to be used with an alarm system, connect this wire with diode.

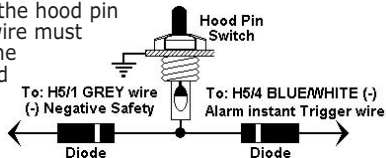

WIRING CONNECTIONS

H5/1 GREY Wire (-) (Negative Safety Shut Down For Hood Switch)

Important! This connection is a safety wire and must be connected as specified. Failure to do so may result in personal injury or property damage. See detail of wiring in the following diagram. This wire may also be used if the vehicle brake light circuit switches ground to the brake lights. An isolation diode must be used for ground switched brake light circuits and must be connected to the output of the brake switch.

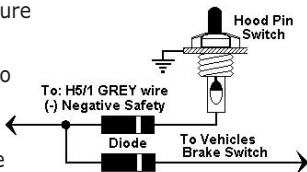

H5/2 BROWN/RED Wire (+) (Positive Safety Shut Down For Brake)

This wire provides an instant shutdown for the remote start, whenever it receives **+12volts**. If the brake lights switch in the vehicle switches **+12 volts** to the brake light circuit, connect this wire to the output side of the brake switch. This will allow the remote start to shut down if an attempt is made to operate the vehicle without the key while running under the control of the remote start. In most vehicles, in order to shift gear, the brake pedal must be depressed. The brake input will in turn cause the remote start unit to shut off. (See diagram.)

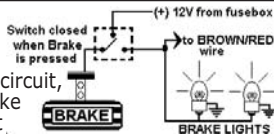

Manual Transmission: When installing on a manual transmission, you also need to connect the **BROWN / RED** wire into the handbrake switch. An isolation diode must be used for handbrake switched light circuits and brake light circuit. Most handbrake wires will show **+12V** at rest when the ignition is on and ground when you set the handbrake. however, if the handbrake wire shows **0V** while the handbrake is at rest, you will need to add a relay as illustrated in the diagram below.

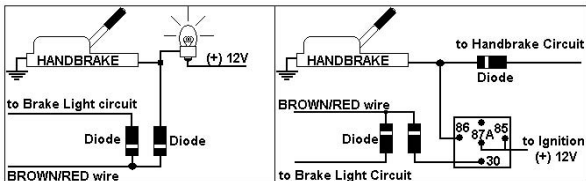

WIRING CONNECTIONS

H5/3 Thin BLACK Wire (Remote Start Enable or Neutral Safety Input)

When the **Thin BLACK** wire is grounded, the remote start unit is operable. When this wire is open from ground, the remote starter is disabled.

1. An optional toggle switch can be added on to this wire to temporarily disable the remote starter. This feature is useful if the vehicle is being serviced or stored in an enclosed area.
2. This wire can also be connected to the neutral safety switch wire in the vehicle.

IMPORTANT NOTE: Directly connect the Thin BLACK wire to ground when not being used. The remote starter will not work if this wire is not grounded.

H5/4 BLUE / WHITE Wire – (-) Instant Trigger or Major trigger Input (Zone 2) –

This wire is the **(-) negative** ground trigger input wire for hood/trunk pin switches.

H5/5 GREY/BLACK Wire (Negative Diesel Wait to Start Input)

The **GREY/BLACK** wire is a **(-) negative** input for diesel vehicles only. This wire will attach directly to the wait to start bulb on the dashboard, or on some vehicles the ECM module. You must locate and test the wire that will provide a ground signal when the wait to start light is on. The correct wire will provide a ground signal when the bulb is on and **+12volt** positive when the bulb is out. There are some vehicles that will have the opposite configuration and you will need to wire a relay to convert the polarity. **(See diagram example below)** You must program the control module for diesel mode. **(See programming Start Feature #1.)**

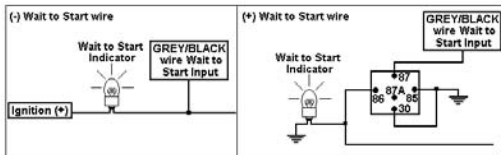

H5/6 GREEN Wire (Negative Door Input) (Zone 3)

The **GREEN** wire is the **(-) negative** ground trigger input for negative style door circuits. This green wire will attach to the wire in the vehicle that provides a ground when any of the doors are opened. The same wire in the vehicle will provide **+12volts** positive or **0 voltage** when the doors are closed.

WIRING CONNECTIONS

H5/7 VIOLET Wire (Positive Door Input) (Zone 3)

The **VIOLET** wire is the positive trigger input for **+12volt** positive style door circuits. The **VIOLET** wire will attach to the wire in the vehicle that provides **+12volt** positive when the door is opened. The same wire in the vehicle will provide **0 voltage** or negative ground when the doors are closed. This type of door circuit is most common with **Ford** vehicles.

H5/8 WHITE/BLACK Wire (Instant Start and Stop Input)

The **WHITE/BLACK** wire will activate and deactivate the remote starter when it sees a momentary **(-) negative** ground. This wire is used for testing purposes and to activate the remote starter from another source.

H5/9 VIOLET / WHITE Wire (Tach. Input or Oil Sensor Connection) (Tach Input Connection)

Note: No connection of this wire is required, if you are using the voltage checking type mode. This input provides the remote start system with information about the engine's revolutions per minute (RPM). It can be connected to the negative side of the coil in vehicle with conventional coils. To test for a tachometer wire, a multi-meter capable of testing **AC voltage** must be used. The tach wire will show between **1V and 6V AC** at idle, and will increase as the engine RPM increases. In multi-coil ignition systems, the control module can learn individual coil wires.

IMPORTANT! Do not test for tach wires with a test light or logic probe.

How to find a tach wire with your multi-meter

1. Set the ACV or AC voltage (12V or 20V is fine.)
2. Attach the (-) probe of the meter to chassis ground.
3. Start and run the vehicle.
4. Probe the wire you suspect of being the tach wire with the red probe of the meter.
5. If this is the correct wire the meter will read between 1V and 6V.

IMPORTANT NOTE: You must program the "Tach Signal" before trying to remote start.

Oil Sensor Signal Connection

Locate the wire connected to the oil sensor on the dashboard or to the generator in the engine compartment.

WIRING CONNECTIONS

Negative Oil Sensor Connections: +12volts to +14volts will show on the multimeter when the ignition switch is turned to the "ON" position in the key cylinder and +2volts to + 3volts when the motor is running.

Positive Oil Sensor Connections: +2volts to + 3volts will show on the multimeter when the ignition switch is turned to the "on" position in the key cylinder and +12volts to +14volts when the motor is running.

IMPORTANT NOTE: You must program for oil sensing type before trying to remote start. (See programming start feature #2.)

H6: 3-PIN DOOR LOCK CONNECTOR:

3-Pin Connector Polarity Output

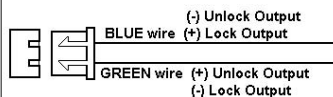

Adding New Actuator

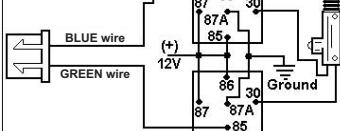

Type "A" (+) Positive Trigger

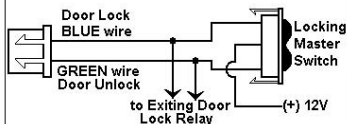

Type "B" Negative Trigger

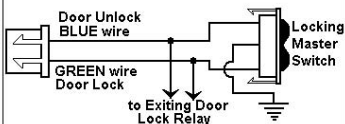

Type "C" 5-wire Locks

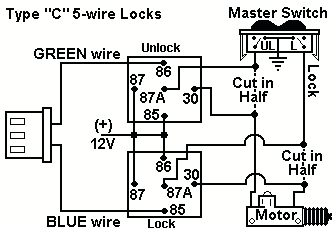

2 Step Door Unlock Type "C"

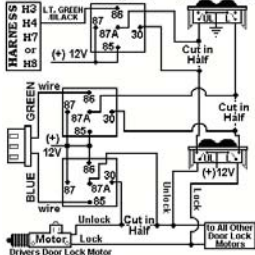

WIRING CONNECTIONS

VACUUM OPERATED DOOR LOCKING SYSTEM: TYPICAL OF MERCEDES BENZ AND AUDI.

Locate the wire under the driver's kick panel. Use the voltmeter connecting to ground, verify that you have the correct wire with the doors unlocked, the voltmeter will receive "12 volts". Lock the doors and the voltmeter will read "0 volt". Move the alligator clip to +12V and the voltmeter will receive "+12 volts". Cut this wire and make your connections. Be sure to program the door lock timer for 3.5 seconds.

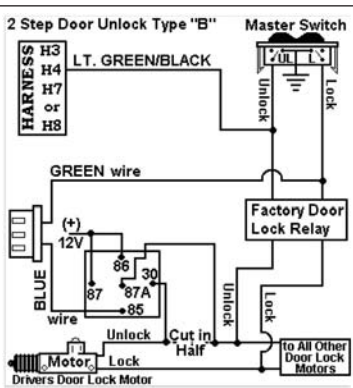
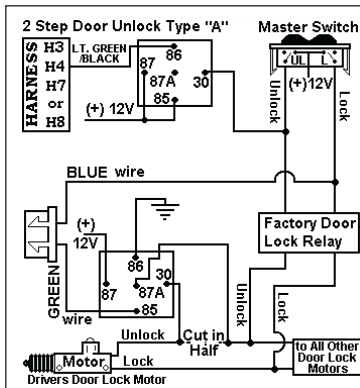
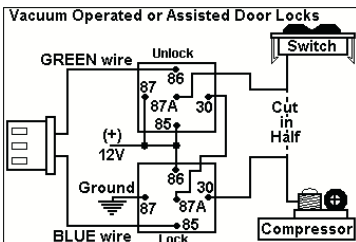

WIRING CONNECTIONS

H7: 4 PIN ORANGE CONNECTOR FOR 2 STAGE SHOCK SENSOR (ZONE 1 / 4)

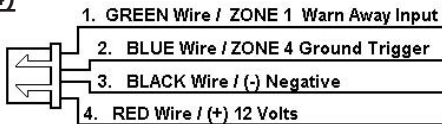

H8: 10-PIN WHITE WIRING HARNESS:

H8/1 BLUE / BLACK Wire (Ignition 3 Output)

This wire provides a **200mA (-) negative** ground output that becomes active 4 seconds before the remote start unit initializes, and remains grounded while running.

Ignition 3 output:

Some newer vehicles use a third ignition wire which is required to start and keep the vehicle's engine running. If this is the case, wire an IGN 3 relay (not supplied) as shown below: Do not connect any vehicle circuits together, they are isolated for a reason.

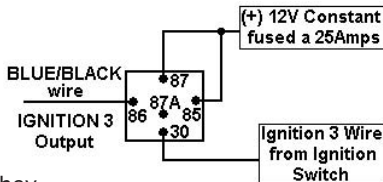

H8/2 BLACK/VIOLET Wire (Timer Control Channel 6 Programmable Output)

The **BLACK/VIOLET** wire provides a 200mA (-) **negative** programmable ground output for a variety of optional devices. The output on the **BLACK/VIOLET** wire is programmable from 1 to 120 seconds. (**See programming instructions.**) This wire can be used to open a sunroof, or any power device you choose to control. The **BLACK/VIOLET** wire must be wired to a relay when powering any devices. **Note: factory default setting is a 1 second momentary ground. (See operating instructions.)**

To activate this feature press the transmitters * and buttons at the same time.

WIRING CONNECTIONS

H8/3 BROWN/BLACK Wire (Horn or Factory Rearm Output)

The **BROWN/BLACK** wire provides a 200mA (-) **negative** output for hooking up to the vehicle's horn relay activation wire. This wire can also be programmed to use as a factory rearm wire. When programmed for factory rearm a (-) **negative** pulse is provided after the remote starter times out or is shut down with the transmitter. **Note: factory default setting is for horn output. (See programming Alarm Feature #3.)**

Factory Security Rearm Signal Output (H8/3 BROWN/BLACK Wire)

This (-) **negative** output is programmable. If programmed for rearming a factory installed security system. This wire will supply a pulse whenever the remote start times out or is shut down using the transmitter and remote door locking.



H8/4 BLACK/WHITE Wire (Dome Light Supervision Output)

The **BLACK/WHITE** wire provides a 200mA (-) **negative** output for 30 seconds when the doors are unlocked using the transmitter. The **BLACK/WHITE** wire will also flash the dome light circuit for the same duration as the siren when violated. **Note: If not attaching the BLACK/WHITE wire directly to the BCM (Body control module) a relay must be used to power the dome light circuit.**

H8/5 BLACK/RED Wire (Timer Control Channel 5 Programmable Output)

The **BLACK/RED** wire provides a 200mA (-) **negative** programmable ground output for a variety of optional devices. The output on the **BLACK/VIOLET** wire is programmable from 1 to 120 seconds. **(See programming instructions).** This wire can be used to open a sunroof, or any power device you choose to control. The **BLACK/RED** wire must be wired to a relay when powering any devices.



Note: factory default setting is a 1 second momentary ground. (See programming instructions.)

To activate this feature press the transmitters  and  buttons at the same time.

WIRING CONNECTIONS

H8/6 VIOLET/BLACK Wire (Timer Control Channel 4 / Key Sensor Output)

The **VIOLET/BLACK** wire provides a 200mA (-) **negative** programmable ground output for a variety of optional devices. The output on the **BLACK/VIOLET** wire is programmable from 1 to 120 seconds. (**See programming instructions**). This wire can be used to open a sunroof, or any power device you choose to control. The **VIOLET/BLACK** wire must be wired to a relay when powering any devices. **Note: factory default setting is a 1 second momentary ground. (See programming instructions for operation of this output)**

Note: this wire can also be programmed as a second start crank output. (See programming instructions). Some vehicles require a second starter wire to be energized, or on certain GM vehicles what is known as the **bulb check** wire must receive a ground signal while the starter is cranking. When using this wire as a second start wire (Most Nissan vehicles) a relay must be used to energize this circuit. To activate this feature, press the transmitters  and  buttons at the same time.

H8/7 RED/WHITE Wire (Channel 3 Trunk Output)

The **RED/WHITE** wire will provide a 1 second 200mA (-) **negative** ground pulse output by activating channel 3 on the transmitter for 2 seconds. This feature will allow a trunk release or other optional devices to activate by remote transmitter. **Note: If not attaching the RED/WHITE wire directly to the BCM (Body control module) a relay must be used to power the trunk or device being energized.**

H8/8 LT.GREEN / BLACK Wire (Step 2 Door Unlock / Factory Disarm Shock Sensor Bypass)

Dual Pulse Door Unlock Output –

The dual pulse door unlock feature will work for most of the fully electronic door lock circuits. When wired for this feature, pressing the disarm (or unlock) button one time will disarm the alarm and unlock the driver's door only. If you press disarm (or the unlock) button two times within 3 seconds, the alarm will disarm and all the doors will unlock. This is a (-) **negative** output.

WIRING CONNECTIONS

Factory Security Disarm Signal Output – Factory Default

This wire is designed to disarm a factory installed security system. This wire sends a **(-) negative** 1 seconds pulse upon a remote start and remote door unlocking. Some factory systems must be disarmed to allow remote starting. In most cases, this wire may be connected directly to the factory alarm disarm wire. The correct wire will show negative ground when the key is used to unlock the doors or trunk. This wire is usually found in the kick panel area in the wiring harness coming into the car body from the door.

Start Status (Shock Sensor By-Pass Control) Output–

This wire is designed to by-pass a shock sensor module. This wire will supply an output at all times the remote start is operating plus an additional 3 seconds after the remote start unit is turned off.

H8/9 ORANGE/WHITE Wire (Ground Output When Disarmed)

The **ORANGE/WHITE** wire provides a 200mA **(-) negative** output when the security system is disarmed. This output can be used for activating optional devices such as memory positions for power seats. **Note: If not attaching the ORANGE/WHITE wire directly to the BCM (Body control module) a relay must be used to power the device being energized.**

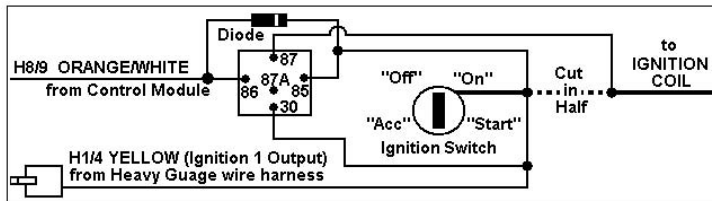

WIRING CONNECTIONS

H8/10 ORANGE Wire (Starter Disable Relay Output)

The **ORANGE** wire will provide a 500mA (-) **negative** output when the security system is armed. A relay with a diode across the coil must be used when interrupting the starter wire. If attaching more than one device to this wire you must diode isolate each device.

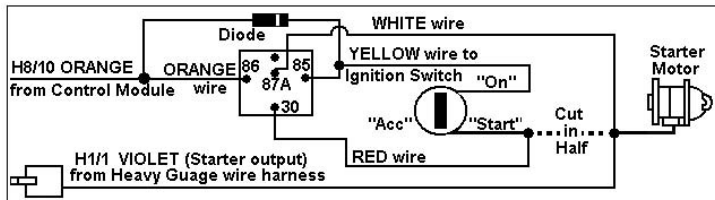

H9: 2-PIN BLUE CONNECTOR FOR THE PROGRAM / VALET SWITCH:

Select a mounting location for the switch that is hidden but easily accessible to the driver of the vehicle. Mount the valet switch in a hidden but accessible location. Route and plug in the valet switch wires to the control module.

H10: 2-Pin White Connector for LED Light

The LED light should be mounted in a highly visible location in the dashboard, center console or dashboard face. Provide for at least a 6mm space behind the LED light. Once a suitable location is chosen, drill a 6mm hole then press the LED housing into the hole. Route the LED wires to the control module and plug it in.

AUTOMATIC OR MANUAL TRANSMISSION

A. AUTOMATIC/MANUAL TRANSMISSION VEHICLE:

Manual Transmission: When you are in manual transmission mode, you also need to connect the **Brown / Red** wire to the emergency or handbrake switch. An isolation diode must be used for the handbrake circuit and brake light circuit.

AUTOMATIC OR MANUAL TRANSMISSION

Most handbrake wires will show **+12V** at rest when the ignition is on and ground when you set the handbrake. However, if the handbrake wire shows 0V while the handbrake is at rest, you will need to add a relay. (See **diagram on page 12.**)

Automatic transmission vehicle: Uncut (leave intact) the **"Violet Loop Wire"**.

Manual transmission vehicle: Cut the **"Violet Loop Wire"** and tape the end.

Note: The system is not recommended for the manual transmission vehicles with removable tops.

Note: When installing this system on a vehicle with a **manual transmission**, the following must be hooked up:

1. **"Brake Light Circuit"** and **"Handbrake Circuit"**. (See **H5/2 BROWN/RED** wire connection.)
2. Negative door pin switch (see **H5/6 GREEN** wire connection.) or positive door pin switch (see **H5/7 VIOLET** wire connection.)

Note: Vehicles with a manual transmission must use "Engine Checking Tach." Or "Engine Checking Oil Sensor." only. (See Start Feature Programming # 2 - 2)

B: PROGRAMMING A REMOTE TRANSMITTER:

Note: The control module will only retain the last 4 remote transmitters programmed. If the transmitter memory is exceeded, the security system will start deleting transmitters from its memory in chronological order.

1. Turn the Ignition switch **"OFF"** and **"ON"** **3 times** and then leave in the **"ON"** position.
2. **Within 15 seconds**, press the **valet/program switch 3 times** and on the **3rd**, **press and hold it** in until 1 long chirp is heard and the LED starts to flash, then release the **valet/program switch**. You are now in the **TRANSMITTER PROGRAMMING MODE**.
3. Press and hold any button on the transmitter until **(1) chirp** from the horn and **(1) flash** from parking lights confirms the first transmitter is now programmed.
4. If you have additional transmitters **(up to 4)** that need to be programmed, repeat step 3 for each transmitter.

PROGRAMMING

Exit: Turn the ignition switch to the “OFF” position, or wait for 15 seconds, **3 long chirps** and **3 parking light flashes** will confirm you have exited programming.



C: FEATURES PROGRAMMING: ALARM FEATURE. #1 PROGRAMMING:

1. Turn the Ignition switch “ON” and “OFF” **3 times** and then leave it in the “OFF” position.
2. Press the **valet/program switch** 2 times and on **2nd** press, hold it in until **1 chirp** is followed by **1 long chirp** then, release the switch. You are now in the **ALARM FEATURE #1 PROGRAMMING MODE.**
3. Press and release the transmitter button that corresponds to the feature you desire to program.
 - a. The number of chirps and LED pauses will indicate the previous setting.
 - b. The factory default settings will always be **[1] LED flash** and **[1] chirp.**
4. Press the transmitter button again to change the feature. Simply keep re-pressing the transmitter button until the module advances to your desired programming setting.

Example:

- a. After you hear **1 chirp**, press the button again and the module will advance to **[2] LED flashes** and **[2] horn chirps.**
- b. Press the button again, the module will advance to **[3] LED flashes** and **[3] chirps** etc.

ALARM FEATURE #1 PROGRAMMING CHART

Press Transmitter Button	One Chirp with One LED Pulse Factory Default Setting	Two Chirps with Two LED Pulses	Three Chirps with Three LED Pulses	Four Chirps with Four LED Pulses
1 	All chirps off	All chirps on	Siren chirp on only	Horn chirp on only
2 	Active arming	Passive arming without passive door locking	Passive arming with passive door locking	Active arming with passive starter disable
3 	Automatic Rearm off	Automatic Rearm on		

PROGRAMMING

ALARM FEATURE #1 PROGRAMMING CHART

Press Transmitter Button	One Chirp with One LED Pulse Factory Default Setting	Two Chirps with Two LED Pulses	Three Chirps with Three LED Pulses	Four Chirps with Four LED Pulses
4 *	45 second delay Door Ajar Warning	Instant Door Ajar Warning		
5 🔒 +*	Panic with Ignition on and off	Panic with Ignition on and off	Panic with Ignition on and off. Panic with no time limit	Without Panic function
6 🔒 +*	Without Car-jack mode	Active Car-jack mode	Passive Car-jack mode	

Exit: Turn the ignition switch to the **"ON"** position, or wait for 15 seconds. **3 long chirps** and **3 parking light flashes** will confirm programming is exited.

Active Arming With Passive Starter Disables: The "Ground-when-armed output will become active 60 seconds after the ignition is turned **"OFF"**. The LED will flash at half its normal rate when the ignition is turned **"OFF"** to indicate that the system will interrupt the Starter/Crank wire in 60 seconds.

45 seconds Delay Door Ajar Warning:







This feature controls the error chirp that is generated if the system is armed with the door trigger active. This is useful in a vehicle that has a Delayed Dome Light after the door has been closed. If the system is armed before the dome light has turned off, the security system will generate the door trigger error chirp. Use this feature to disable the door open error chirp.

ALARM FEATURE #2 PROGRAMMING:

1. Turn the Ignition switch **"ON"** and **"OFF"** **3 times**, leave it in the **"OFF"** position.
2. Press the **valet/program switch 4 times** and hold the **4th** press, hold it in until **2 chirps** followed with **1 long chirp** is heard, then release the **valet/program switch**. You are now in the **ALARM FEATURE #2 PROGRAMMING MODE**.
3. Press and release the transmitter button that corresponds to the feature you desire to program.

PROGRAMMING

ALARM FEATURE #2 PROGRAMMING CHART

Press Transmitter Button	One Chirp with One LED Pulse Factory Default Setting	Two Chirps with Two LED Pulses	Three Chirps with Three LED Pulses	Four Chirps with Four LED Pulses
1 	0.9-second door lock pulse	3.5-second door lock pulse	Double pulse unlock	Door lock with "Comfort Feature"
2 	Ignition controlled door lock & unlocks	Ignition controlled door lock only	Ignition controlled door unlock only	Without ignition controlled door lock and unlock
3 	Pathway illumination feature "off"	Parking light turns "on" for 30-seconds upon an unlock signal	Parking light turns "on" for 30-seconds upon and unlock signal & 10-seconds upon a lock signal	
4 	Disable the out of range check	Enable the out of range check		
5  + 	Override without Password Pin Code	Override with Password Pin Code		

Exit: Turn the ignition switch to the **"ON"** position, or wait for 15 seconds. **3 long chirps** and **3 parking light flashes** will confirm the programming was exited.

Comfort Feature:

Some vehicles have a special comfort feature. When you lock the driver's door with the key, and hold the key in the door for 5 to 7 seconds, all the windows in the vehicle will roll up. If you would like to operate this feature with the remote transmitter, you can program the alarm feature # **2-1** to **"COMFORT FEATURE"**.

Password Pin Code Setup:

1. Turn the Ignition switch **"ON"** and **"OFF"** **3 times** and then leave it in the **"OFF"** position.

PROGRAMMING

2. Press the **valet/program switch 4** times then hold it in on the **4th** press until **two chirps** with **1 long chirp** is heard, then release the **valet/program switch**. You are now in the **Alarm feature #2 programming mode**.
3. Press and release the transmitters **🔒** and *** buttons** at the same time twice, **[2] LED flashes, [2] chirps** to indicate the system is in the feature **"Password Pin Code Programming mode"**
4. Within 5 seconds, begin to enter your chosen first 9 digits by pressing and releasing the **valet/program switch** from 1 – 9 times.
5. Within 15 seconds of the last entered 9ths digit, turn the Ignition switch to **"ON"** position.
6. Within 15 seconds, enter your chosen second 9ths digit by pressing and releasing the **valet/program switch** from 1 – 9 times.
7. Finish by turning the ignition switch to the **"OFF"** position. If the new password code was accepted, the unit will respond back with the newly entered code, by flashing the LED, indicating the first digit code has been memorized, pause and then the second digit code. The unit will repeat the new code three times with a one-second pause between each code. Note: If 15 seconds of inactivity expires, or if the ignition switch is turned **"ON"** for more than 5 seconds during the above steps, the unit will revert back to the last successfully stored code. **[3] long chirps** will confirm you have exited the program. The unit will revert back to the last successfully stored code.

Delete Password Pin Code / Override Without a Password Pin Code (Factory default setting):

1. Turn the Ignition 'switch **"ON"** and **"OFF"** 3 times and then to the **"OFF"** position.
2. Press the **valet/program switch 4 times** and then hold in on the **4th** press until **two chirps** with **1 long chirp** is heard, then release the **valet/program switch**. You are now in the **ALARM FEATURE #2 PROGRAMMING MODE**.
3. Within 15 seconds, press and hold the transmitters **🔒** and *** buttons** at the same time for 3 seconds. **1 long chirp** will confirm the Password Pin Code is deleted.

Exit: Press any button (except the **🔒 button**) of the transmitter to exit the password pin set up mode.

ALARM FEATURE # 3 PROGRAMMING:

- 1 Turn the Ignition switch **"ON"** and **"OFF"** 3 times, then to the **"OFF"** position.

PROGRAMMING

2 Press the **valet/program switch 6 times** and hold it in on the **6th** press until **3 chirps** followed with **1 long chirp** is heard and the LED turns on then release the **valet/program switch**. You are now in the **ALARM FEATURE #3 PROGRAMMING MODE**.

3 Press and release the transmitter button that corresponds to the feature you desire to program.

ALARM FEATURE #3 PROGRAMMING CHART

Press Transmitter Button	One Chirp with One LED Pulse Factory Default Setting	Two Chirps with Two LED Pulses	Three Chirps with Three LED Pulses	Four Chirps with Four LED Pulses
1	H2/5 Brown Wire =Constant Siren Output	H2/5 Brown Wire =5-second Pulse Siren Output	H2/5 Brown Wire =Random Pulse Siren Output	H2/5 Brown Wire =Horn Output
2	H8/8 Lt. Green/Black Wire =Factory Security Disarm Signal Output	H8/8 Lt. Green/Black Wire =Dual Pulse Door Unlock Output	H8/8 Lt. Green/Black Wire = Start Status Output (Shock Sensor Bypass)	
3	H5/8 White/Black Wire =1 Pulse Activate	H5/8 White/Black Wire = 2 Pulses Activate	H5/8 White/Black Wire = 3 Pulses Activate	
4	H8/3 Brown/Black Wire = (-) 200ma Horn Output	H8/3 Brown/Black Wire = Factory Security Rearm Signal Output		
5 +	H8/6 Violet/Black Wire Channel 4 Output= Momentary Output	H8/6 Violet/Black Wire Channel 4 Output= Latched Output	H8/6 Violet/Black Wire Channel 4 Output= Latched Output & Reset with Ignition "on"	H8/6 Violet/Black Wire Channel 4 Output= Timer Programming (set to any interval between 1 sec. and 2 min.)
5 Chirps =H8/6 Violet/Black Wire = Ground Output During Start (crank)				

PROGRAMMING

ALARM FEATURE #3 PROGRAMMING CHART

Press Transmitter Button	One Chirp with One LED Pulse Factory Default Setting	Two Chirps with Two LED Pulses	Three Chirps with Three LED Pulses	Four Chirps with Four LED Pulses
6 +	H8/5 Black/Red Wire Channel 5 Output= Momentary Output	H8/5 Black/Red Wire Channel 5 Output=Latched Output	H8/5 Black/Red Wire Channel 5 Output=Latched Output and Reset with Ignition "on"	H8/5 Black/Red Wire Channel 5 Output=Timer programming (set to any interval between 1 sec- ond and 2 min.)
7 +	H8/2 Black/Violet Wire Channel 6 Output= Momentary Output	H8/2 Black/Violet Wire Channel 6 Output=Latched Output	H8/2 Black/Violet Wire Channel 6 Output=Latched Output and Reset with Ignition "on"	H8/2 Black/Violet Wire Channel 6 Output=Timer programming (set to any interval between 1 sec- ond and 2 min.)

Exit: Turn the ignition switch to the "ON" position, wait 15 seconds you will get 3 long chirps and 3 parking light flashes, this will confirm the programming has been exited.

Channels 4 (5/6) Timer Control Output Programming.

1. Turn the Ignition switch "ON" and "OFF" 3 times, then leave it in the "OFF" position.
2. Press the **valet/program switch 6 times** and then hold it in on the **6th** press until **3 chirps** followed by **1 long chirp** is heard and the LED will turn on, release the **valet/program switch**. You are now in the

Alarm feature # 3 programming mode.

- 3-a. Press and release the transmitters and buttons together **4 times**, [**4**] LED flashes and [**4**] siren or horn chirps will indicate you are in "CHANNEL 4 TIMER PROGRAMMING MODE".
- 3-b. Press and release the transmitters and buttons together **4 times**, [**4**] LED flashes and [**4**] siren or horn chirps will indicate you are in "CHANNEL 5 TIMER PROGRAMMING MODE".

PROGRAMMING

- 3-c. Press and release the transmitters **Ⓜ** and ***** buttons together **4 times**, **[4] LED flashes** and **[4] siren or horn chirps** will indicate you are in **"CHANNEL 6 TIMER PROGRAMMING MODE"**.
4. Press and hold the **valet/program switch**, the timer will immediately start.
5. When the desired interval has passed, release the **valet/program switch**. **1 long chirp** will be heard for confirmation. **(Set to any interval between 1 second and 2 minutes.)**

Note 1:

If your built-in timer controls the windows or a sunroof in your vehicle, **DO NOT change the timer setting!** This requires installer-only programming. Changing the value will adversely effect operation and may cause damage to the motors.

Note 2:

Momentary output The momentary output selection will provide a negative signal from the Channel 4 (5/6) output immediately when the **channel 4 (5/6) button** is pressed and will continue until the button is released.

Latched output The latched output selection will provide a negative signal as soon as the Channel 4 (5/6) button is pressed and will continue until the button is pressed again

Latched output / reset with ignition The latched / reset with ignition output selection operates just like the latched output but will reset or stop when the ignition is turned on.

Ground Output During Start (Crank) This wire will provide a 200 mA (-) **negative** ground output while the starter output of the control module is active. This output can be used to activate the Crank Low/Bulb Test wire found in some GM vehicles. This wire is also referred to as the ECM wake up wire in some vehicles.

START FEATURE. # 1 PRORAMMING:

1. Turn the Ignition from **"ON"** to **"OFF"** **3 times**, then to the **"OFF"** position.
2. Press the **valet/program switch 8 times** and then hold it in on the **8th** press until **four** chirps followed with 1 long chirp is heard and the LED will turn on, release the **valet/program switch**. You are now in the **"START FEATURE #1 PROGRAMMING MODE"**.
3. Press and release the transmitter button that corresponds to the feature you desire to program.

PROGRAMMING

START FEATURE CHART #1

Press Transmitter Button	One Chirp with One LED Pulse Factory Default Setting	Two Chirps with Two LED Pulses	Three Chirps with Three LED Pulses	Four Chirps with Four LED Pulses
1 +	Gasoline Engine Diesel Engine with Wait-to-Start Light (H5/5 Grey/ Black Wire must be connected)	Diesel Engine without Wait-to-Start Light 10 seconds warm-up timer	Diesel Engine without Wait-to-Start Light 15 seconds warm-up timer	Diesel Engine without Wait-to-Start Light 20 seconds warm-up timer
2	20 Minute Run Time	30 Minute Run Time	5 Minute Run Time	10 Minute Run Time
3	Factory Alarm Disarm with Channel 3 On	Without this Feature		
4	Constant Parking Light Output	Flashing Parking Light Output		
5 *	Without this Feature	Door Lock Before Start	Door Lock After Shut-Down	Door Lock Before Start and Door Lock After Shut-Down
6 + *	Press * - * Button=Activate Remote Start	Press + * Button=Activate Remote Start	Press * button = Activate Remote Start	
7 + *	Fahrenheit Display for Temperature	Celsius Display for Temperature		
8 + *	Temperature-Control I Starting OFF	Temperature-Control Starting 5F (-15C)	Temperature-Control Starting - 4F (-20C)	Temperature-Control Starting - 22F (-30C) 30

PROGRAMMING

Exit: Turn Ignition to "ON" position, or leave it for 15 seconds. **3 long chirps** and **3 parking light flashes** will confirm programming exit.

SAFE START (Child safety mode)

Factory defaults setting to press the *** button twice** to start the vehicle. Programming this feature to eliminate an accidental remote start, when kids enter this transmitter, it requires: The user press the transmitters **🔒** and *** buttons** at the same time to start the vehicle.

START FEATURE # 2 PROGRAMMING:

1. Turn the Ignition switch "ON" and "OFF" **3 times** and leave it in the "OFF" position.
2. Press the **valet/program switch 10 times** and then hold it in on the **10th** press until **five chirps** followed by **1 long chirp** is heard, release the **valet/program switch**. You are now in the "START FEATURE # 2 PROGRAMMING MODE".
3. Press and release the transmitter button that corresponds to the feature you desire to program.

START FEATURE CHART #2

Press Transmitter Button	One Chirp with One LED Pulse Factory Default Setting	Two Chirps with Two LED Pulses	Three Chirps with Three LED Pulses	Four Chirps with Four LED Pulses
1 🔒	Exit the programming mode. (3 long chirps and 3 parking light flashes will confirm programming exit.)			
2 🔒+🔒	Engine Checking Voltage	Engine Checking TACH / RPM Learning Mode	Engine Checking Negative Oil Sensor	Engine Checking Positive Oil Sensor
3 🔒	Start Timer: 0.6-second	0.8-second (2 chirps), 1.0-second (3 chirps) 1.2-second (4 chirps), 1.4-second (5 chirps), 1.6-second (6 chirps), 1.8-second (7 chirps), 2.0-second (8 chirps), 3.0-second (9 chirps), 4.0-second (10 chirps).		
4 🚫	Low check level	Hi check level		
5 * - *	Start or stop the system for TESTING AND ADJUSTMENT			
6 🔒+*	3 Hour Time Start	2 Hour Time Start		

PROGRAMMING

START FEATURE CHART #2

Press Transmitter Button	One Chirp with One LED Pulse Factory Default Setting	Two Chirps with Two LED Pulses	Three Chirps with Three LED Pulses	Four Chirps with Four LED Pulses
7 + *	The Vehicle without Turbo (The system cannot be Arm with the engine is running.	The Vehicle has aftermarket Turbo timer installed. The system can be Arm with engine running and the shock sensor will be bypass as long as the engine is running.	The Vehicle has aftermarket Turbo timer installed: The system can be Arm with the engine running and the shock sensor will be bypass for three minutes.	Built-in Turbo Timer Control is Active: Press + * buttons at the same time to set engine running for one minute.
		Five chirps =Built-in Turbo Timer Control is active. Press + * buttons at the same time to control engine running 3 minutes. Six chirps =Built-in Turbo Timer Control is active. Press + * buttons at the same time to control engine running five min.		
8 + *	"Test" Mode for Zone 2 / Instant Trigger & Zone 3 / Door Trigger	"Test" Mode for Zone 1 & Zone 4 (2 Stage Shock Sensor)		

Exit: Press the button on the transmitter. **3 long chirps** and **3 parking light flashes** will confirm the program is exited.

IMPORTANT NOTE: You must program the "Tach Signal" before trying to remote start.

ENGINE CHECKING TACH. / RPM LEARNING

1. Turn the Ignition switch "ON" and "OFF" **3 times** and leave it in the "OFF" position.
2. Press the **valet/program switch 10 times** and then hold in on the **10th** press until **5 chirps** with **1 long chirp** is heard, then release the **valet/program switch**.
3. Press and release the transmitters and buttons at the same time twice [**2**] LED flash, [**2**] chirps to confirm the system is in feature "RPM Learning mode".

PROGRAMMING

4. Within 10 seconds, start the vehicle with the key. (While the engine is running, the parking lights and LED will flash, If not, please check **VIOLET/WHITE** wire connection. **(H5/9)**)
5. Press and hold the **valet/program switch** for 2 seconds or until **1 long chirp** and the LED lights constant for two seconds. The RPM signal is learned.
6. Turn **OFF** the ignition switch to SHUT DOWN the engine.
Once you complete step 6, you can adjust and test the **"Check Level"** as below:

CHECK LEVEL PROGRAMMING: (TEST and ADJUST)

1. Press the *** button twice** on the transmitter to start the vehicle.
2. If the engine starts:
 - a. Press the *** button twice** on the transmitter to stop the engine. You have completed this programming successfully.
 - b. Press the **🔒 button** on the transmitter to exit the program mode. There will be **3 long chirps** and **3 parking light flashes** for confirmation.
3. If the crank time is too short, (Engine not running, but stops cranking):
 - a. Press the *** button** on the transmitter to turn off the ignition. Press the **🔧 button** on the transmitter to set the proper **"Check Level"** to Hi position. **[2] LED flashes** and **[2] chirps** will confirm this setting.
 - b. Repeat the step1 – 4.
4. If the crank time is too long, (if the engine is running successfully, but the starter still cranks):
 - a. Press the *** button** on the transmitter to stop. Press the **🔧 button** on the transmitter to set the proper **"Check Level"** to Low position. **[1] LED flash** and **[1] chirp** will confirm this setting
 - b. Repeat the step1 – 4.

ENGINE CHECKING VOLTAGE

1. Turn the Ignition 'switch **"ON"** and **"OFF"** 3 times and leave it in the **"OFF"** position.
2. Press the **valet/program switch 10 times** and then hold it in on the **10th** press until **five chirps** with **1 long chirp** is heard, release the **valet/program switch**.
3. Press the transmitters **🔒** and **🔑** buttons at the same time to set the **"Engine Checking Voltage"**. **[1] LED flash**, and **[1] chirp** to confirm this setting

Once you complete step 3, you can adjust and test **"Start Timer"** as follows:

PROGRAMMING

START TIMER PROGRAMMING: (TEST and ADJUST)

1. Press the *** button twice** on the transmitter to start the vehicle.
2. If the engine starts, Wait for 15 seconds:
 - a. If the engine is still running.
 - I. Press the *** button twice** on the transmitter to stop the engine. You have completed this programming successfully.
 - II. Press the **🔒 button** on the transmitter to exit the program mode. There will be **3 long chirps** and **3 parking light flashes** for confirmation.
 - b. If the engine shuts down after the vehicle has been started.
 - I. Press the *** button twice** on the transmitter to stop the engine.
 - II. Press the **🔒 button** on the transmitter to set "**Check Level**" to LOW position. **[1] LED flash**, and **[1] chirp** to confirm this setting.
 - III. Repeat the step1 - 2.
3. If the crank time is too long, (Engine is running, while starter is still cranking):
 - a. Press the *** button twice** on the transmitter to stop the engine.
 - b. Press the **🔒 button** on the transmitter to set the proper "**Start Timer**". The 1 chirp and LED pause will confirm you have entered this programming. (Decrease "**Start Timer**" is necessary.)
 - c. Repeat the step1 - 4.
4. If the crank time is too short, (Engine cranks but does not start):
 - a. Press the *** button twice** on the transmitter to stop.
 - b. Press the **🔒 button** on the transmitter to set proper "**Start Timer**". The 1 chirp and LED pause will confirm you have entered this programming. (Increase "**Start Timer**" is necessary.)
 - c. Repeat the step1 - 4.

ENGINE CHECKING OIL SENSOR

1. Turn the Ignition switch "**ON**" and "**OFF**" **3 times** and leave it in the "**OFF**" position.
2. Press the **valet/program switch 10 times** and hold in on the **10th** press until **five chirps** with **1 long chirp** is heard, then release the **valet/program switch**.
3. Press the transmitters **🔒** and **🔒 buttons** at the same time to set the "**Engine Checking Oil Sensor**". **[3] / [4] LED flashes**, **[3] / [4] chirps** to confirm this setting.

Once you have completed step 3, you can adjust and test "**Start Timer**" as follows:

PROGRAMMING

START TIMER PROGRAMMING: (TEST and ADJUST)

1. Press the *** button twice** on the transmitter to start the vehicle.
2. If the engine starts:
 - a. Press the *** button twice** on the transmitter to stop the engine. You have completed this programming successfully.
 - b. Press the **🔒 button** on the transmitter to exit the program mode. There will be **3 long chirps** and **3 parking light flashes** for confirmation.
3. If the crank time is too long, (Engine is running, while the starter still cranks):
 - a. Press the *** button twice** on the transmitter to stop.
 - b. Press the **🔒 button** on the transmitter to set proper **"Start Timer"**.
 - 1 chirp and the LED pause will confirm this programming is entered. (Decrease **"Start Timer"** is necessary.)
 - c. Repeat the step 1 – 4.
4. If the crank time is too short, (Engine cranks but does not start):
 - a. Press the *** button twice** on the transmitter to stop.
 - b. Press the **🔒 button** on the transmitter to set the proper **"Start Timer"**. The **1 chirp** and the LED pause will confirm this programming is entered. (Increase **"Start Timer"** is necessary.)
 - c. Repeat the step 1 – 4.

ALARM TEST MODE

In this test mode, the system can test the Zone 2 (Instant ground trigger), the Zone 3 (Door trigger), and the Zone 1 and Zone 4 (2 stage shock sensor) sensitivity. The installer can save time to test the 2 stage shock sensor sensitivity and sensor without using the traditional arming/disarming procedures to test the sensors.

Enter:

1. Turn the Ignition switch **"ON" and "OFF" 3 times** and leave it in the **"OFF"** position.
2. Press the **valet/program switch (10) times** and hold it in on the **10th** press, until **(5) five chirps** with **(1) long chirp** is heard, then release the **valet/program switch**. You are now in the **"START FEATURE #2 PROGRAMMING MODE"**.
 - a. **Test the Zone 2 / Instant Ground Trigger & Zone 3/Door Trigger:**
Press and release the transmitters **🔒** and *** buttons** at the same time once. **[1] LED flash** and **[1] chirp** will indicate the system is in **Zone 2/ instant ground trigger and Zone 3 /Door trigger test mode.**³⁵

ALARM TEST MODE

Trigger sensor	Siren chirps
Zone 2 / Instant Ground trigger (H5/4 BLUE/WHITE wire)	2
Zone 3 / Door trigger (H5/6 GREEN or H5/7 VIOLET wire)	3

b. Test the Zone 1 & Zone 4 / Two Stage Shock Sensor (Connected to H7/4 Pin Plug):

Press and release the transmitters **🔑** and **★** buttons at the same time again. **[2] LED flashes** and **[2] chirps** will indicate the system is in the shock sensor (connected to H7/4 pin plug) test mode.

1. Activate the warn-away (**first stage of the shock sensor / Zone 1**), system will emit a short chirp.
2. Activate the full alarm (**second stage of the shock sensor / Zone 4**), system will emit a long chirp.
3. Continue to test the shock sensor until reaching the proper sensitivity.

RETURN TO FACTORY DEFAULT SETTING

Turn the ignition "ON" and "OFF" (3) TIMES and leave it in the "OFF" position.

1. Press the **valet/program switch 12 times** and hold it in on the **12th** press until **(6) chirp** with **(1) long chirp** is heard, then release the **valet/program switch**. You are now in the **"Return To Factory Default Setting" programming mode.**

ALARM FEATURE, RETURN ALL TO FACTORY DEFAULT SETTINGS:

2. Press and hold the **🔒** and **🔑** buttons at the same time on the transmitter for 5 seconds, there will be a confirmation of six chirp with **3 long chirps** to confirm the system **"Alarm Feature #1, 2 and 3 Programming** all return to factory default setting.

START FEATURE, RETURN ALL TO FACTORY DEFAULT SETTINGS:

3. Press the **🔑** button first, within 3 seconds press **🔒** and **🔑** hold the **🔒** and **🔑** buttons at the same time on the transmitter for 5 seconds, there will be a confirmation of **(6) chirps** with **(3) long chirps** to confirm the system **"Start Feature 1 & 2 Programming** all returns to factory default setting.

SHUTDOWN DIAGNOSTICS

SHUTDOWN DIAGNOSTICS

The unit has the ability to report the cause of the last shutdown of the remote starter system.

1. Turn the Ignition switch to the **"ON"** position.
2. Press the  **button** on the transmitter.
3. The LED will now report the last system shutdown by flashing for one minute in the following grouped patterns:

LED Flashes	Shutdown Mode	
1	(-) Safety Shutdown Input (Hood)	1.Close the Hood 2.Check H5/1 GREY wire connection
2	(+) Safety Shutdown Input (Brake) or Hand Brake (if installed or Neutral Safety Switch input fail	1.Set the Hand Brake (if installed) 2.Check H5/2 BROWN/RED wire connection. 3.Move the Enable Toggle Switch to "ON" position. (if installed) 4.Move the gear selector to "Park"/"Neutral" position. 5.Check H5/3 THIN BLACK wire connection.
3	No RPM (Engine Checking TACH) or Low Voltage. (Engine Checking Voltage) or Oil Sensor (Engine Checking Oil Sensor)	Check H5/9 VIOLET/WHITE wire connection. Program the "CHECK LEVEL" from "Hi Check Level" to "Low Check Level" Check H5/9 VIOLET/WHITE wire connection.
4	Wait-to-start time out	Check H5/5 GREY/BLACK wire connection
5	Over-rev	
6	System timed out	
7	Transmitter	
8	Tach. Signal has not been learned	Re-learning the RPM (Start feature #2-2)

SHUTDOWN DIAGNOSTICS

LED Flashes	Shutdown Mode
9	The procedure of the Engine start memorizing for the vehicle with manual transmission gear is not completed. Check Operation Manual Remote Start Operation Section.

TESTING YOUR INSTALLATION TECHNIQUES:

Caution!! The follow procedure must be performed after the installation of the remote starter device. It is the responsibility of the installing technician to complete these tests. Failure to test the unit in the following manner may result in personal injury, property damage, or both.

1. Test the brake shutdown circuit: With the vehicle in park (P), start the vehicle using the remote transmitter. Once the engine is running, press the brake pedal. The vehicle should shut down immediately. If the vehicle continues to run, check the brake circuit **BROWN/RED** wire (**H5/2**) connection.
2. Test the hood safety shutdown circuit: Start the vehicle using the remote transmitter. Once the engine is running, pull the hood release and raise the hood. The vehicle should shut down immediately. If the vehicle continues to run, check the hood pin **GREY** wire (**H5/1**) connection.

NEUTRAL START SAFETY TEST

1. Set the vehicle parking brake.
2. Block the drive wheels to prevent vehicle movement.
3. Sitting in the vehicle, turn the ignition switch to **on** or **run** position, but do not start the engine.
4. Step on the brake pedal and shift the gear selector into "DRIVE" (D).
5. Put your foot over the brake pedal but do not press down on it. Be ready to step on the brake to shut down the remote starter device.
6. Start the vehicle using the remote transmitter.
 - a. If the starter does not engage, the test is complete.
 - b. If the starter engages, immediately step on the brake pedal to shut down the system and check your **VIOLET** wire **H1/1** starter output connection. The heavy gauge **VIOLET** wire must be connected to the ignition switch side of the neutral safety switch. If the vehicle you are working on does not have an Electrical Neutral Safety Switch, it will be necessary to reconfigure the remote starts wiring to accommodate this vehicle. The information concerning the mechanical neutral safety switch provided below will help you to determine if the vehicle you are working on has

NEUTRAL START SAFETY TEST

this type of safety switch and will provide alternate wiring methods to accommodate this situation.

MECHANICAL NEUTRAL SAFETY SWITCH CONSIDERATIONS:

Mechanical neutral safety switch configurations differ slightly in that they do not offer the same level of safety when installing a remote start device. Often when the ignition switch is turned off while the gear selector is in any position other than park or neutral, the mechanical function will not allow the key to be turned to the start position or removed from the ignition cylinder. This configuration prevents mechanical operation while the vehicle is in gear but offers no consideration for the electrical operation. Because of this potential problem, your installation requires the additional connection of a safety wire from the remote start device to the vehicle PARK/NEUTRAL ECM input or the vehicle key in sensor wire. This connection will prevent remote start operation if the key is left in the ignition switch regardless of the gear selector position.

PARK/NEUTRAL ECM INPUT:

The Park/Neutral ECM input is the preferred method of installation. This not only maintains the integrity of the factory circuit but is also the easiest to install, providing the vehicle you are working on has this ECM input.

The installation required for this application (shown below), is a slight reconfiguration of the control switch wiring. Shown is a typical GM Park/Neutral ECM input circuit. To connect the remote start unit to the GM Park/Neutral ECM input:

1. Locate the **ORANGE/BLACK** reference wire in the "C2" connector found at the ECM in GM B Body vehicles or, locate the equivalent reference wire in the vehicle you are installing the remote start unit in.
2. Connect the **Thin BLACK** Neutral Safety Switch wire (**H5/3**) to this reference wire.

NOTE: If the optional remote starter enable toggle switch is installed, connect the one side of the switch to this reference wire the other side of to the **Thin BLACK** Neutral Safety Switch wire (**H5/3**) of the remote start unit. The reference diagram below shows a typical GM B Body ECM reference wire and how to connect it to the remote start unit.

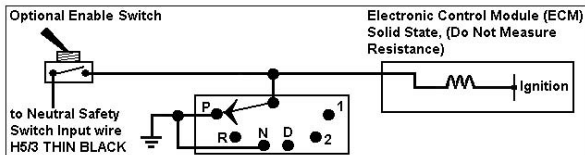

KEY IN SENSOR CIRCUITS

If the vehicle you are working on does not have or you cannot locate the ECM reference wire, there are two alternatives available. Although not preferred, the vehicle key in sensor may be reconfigured to allow a margin of safety and will prevent the vehicle with a mechanical neutral start switch from starting in gear.

WE ADVISE THAT YOU MAINTAIN THE FACTORY CIRCUIT WHENEVER POSSIBLE. The following two circuits may be used only if the above circuit is not available.

NOTE: When completing an installation using either of the following key in sensor circuits, if the operator inserts the ignition key while the vehicle is running under the control of the remote start, the vehicle will shut down. This must be explained to the operator as it is in contrast to the normal operation of a vehicle utilizing an electrical neutral start switch and is inconsistent with the operator's manual.

Method 1 will allow the safety required for the remote start unit and prevent the vehicle from starting while in any gear other than Park or Neutral while the key is in the ignition cylinder however, if the key is left in the ignition switch and the door is left opened, the added relay will be energized causing a 150mA drain on the battery.

Method 2 will allow the safety required for the remote start unit and prevent the vehicle from starting while in any gear other than Park or Neutral while the key is in the ignition cylinder however, the original factory key in chime module will not alert the owner that the key has been left in the ignition switch. In addition, this may also affect other warning tones such as the light on reminder.

Note:

Additional information concerning key in sensor methods 1 and 2 are listed below and should be reviewed before considering either alternative.

KEY IN SENSOR CIRCUITS

KEY IN SENSOR CIRCUITS:

If the vehicle you are working on does not have or you cannot locate the ECM reference wire, there are two alternatives available. Although not preferred, the vehicle Key In Sensor may be reconfigured to allow a margin of safety and will prevent the vehicle with a Mechanical Neutral Start Switch from starting in gear.

WE ADVISES THAT YOU MAINTAIN THE FACTORY CIRCUIT WHENEVER POSSIBLE. The following two circuits may be used only if the above circuit is not available.

NOTE: When completing an installation using either of the following key in sensor circuits, if the operator inserts the ignition key while the vehicle is running under the control of the Remote Start, the vehicle will shut down. This must be explained to the operator as it is in contrast to the normal operation of a vehicle utilizing an electrical neutral start switch and is inconsistent with the operators manual.

Additional information concerning Key in Sensor methods 1&2 are listed below and should be reviewed before considering either alternative.

Method 1 will allow the safety required for the remote start unit and prevent the vehicle from starting while in any gear other than Park or Neutral while the key is in the ignition cylinder however, if the key is left in the ignition switch and the door is left opened, the added relay will be energized causing a 150mA drain on the battery.

Method 2 will allow the safety required for the remote start unit and prevent the vehicle from starting while in any gear other than Park or Neutral while the key is in the ignition cylinder however, the original factory key in chime module will not alert the owner that the key has been left in the ignition switch. In addition, this may also effect other warning tones such as the light on reminder.

These situations should be carefully considered before altering the vehicle's wiring and must be fully explained to the consumer.

METHOD 1

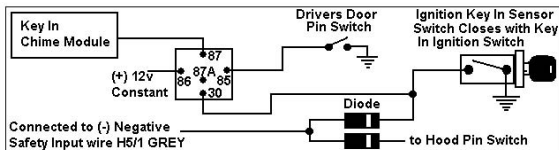

PROGRAMMING

To connect to the key in sensor as shown in method 1:

- A. Locate the control wire that connects the driver's door pin switch to the key in sensor switch.
- B. Cut this wire and connect the ignition cylinder side to a chassis ground.
- C. Locate the key in sensor switch wire that connects the chime module to the ignition cylinder.
- D. Cut this wire and connect the ignition cylinder side to terminal 30 of a P&B VF45F11 or equivalent relay.
- E. Connect the cathode (striped) side of a 4003 series diode to this same wire, and connect the (non striped) side to the negative safely input wire (**GREY**) (**H5/1**) of the remote start unit.
- F. Connect terminal 86 of the relay to a fused + 12 volt constant battery source.
- G. Connect terminal 87 of the relay to the chime module side of the previously cut wire in step D.
- H. Connect terminal 85 of the relay to the driver's door side of the pin switch wire previously cut in step B.

Note: A second **4003 series diode** may be required to maintain the integrity of the hood open, shut down circuit. If this is the case, it must be installed as shown in the diagram above. The anode (Non Stripped) side must be connected to the **GREY** wire (**H5/1**) of the remote start unit. The cathode (Striped) side must be connected to the hood pin switch.

METHOD 2

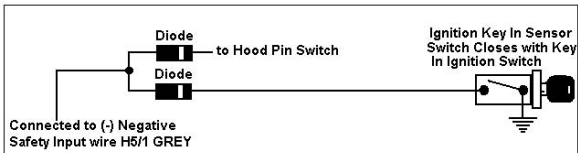

To connect to the key in sensor circuit as shown for method 2:

- A. Locate the control wire that connects the driver's door pin switch to the key in sensor switch.
- B. Cut this wire and connect the ignition cylinder side to chassis ground.
- C. Locate the key in sensor switch wire that connects the chime module to the ignition cylinder.
- D. Cut this wire and connect the ignition cylinder side to the Remote Start Negative Safety Shut down wire **GREY** (**H5/1**), using a **4003 series diode** as shown above.

Note: A second **4003 series diode** may be required to maintain the integrity of the hood open, shut down circuit. If this is the case, it must be installed as shown in the diagram above. The anode (Non Stripped) side must be connected to the **GREY** wire (**H5/1**) of the remote start unit. The cathode (Striped) side must be connected to the hood pin switch.

AFTER THE CONNECTION OF THE NEUTRAL START SAFETY WIRE AS INDICATED IN ANY OF THE PREVIOUS ALTERNATE CONFIGURATIONS, THIS CIRCUIT MUST BE TESTED FOR OPERATION. Retest by following the steps outlined in the NEUTRAL START SAFETY TEST shown in this manual.



©2004 JBS Technologies
225 Technology Way • Steubenville, OH 43952
www.alertautomotive.com

Made in Taiwan